

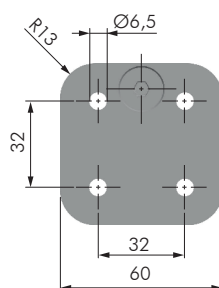

CARATTERISTICHE:

- Giunzione a scomparsa per banconi e penisole della cucina.
- Formata dalla piastra e dal perno antisfilamento.
- Ideale per il fissaggio del piano con il fianco.
- Unisce il mobile in modo solido e stabile.

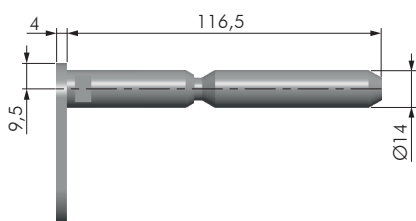
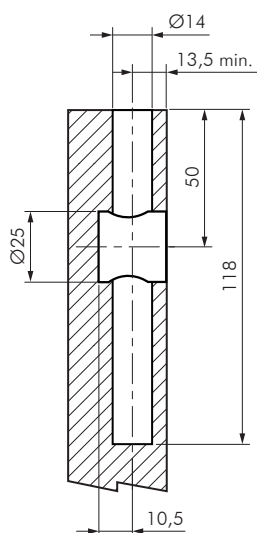

SUPPORTO BANCONE		
CODICE	MATERIALE	QUANTITÀ
91504030	FE	50

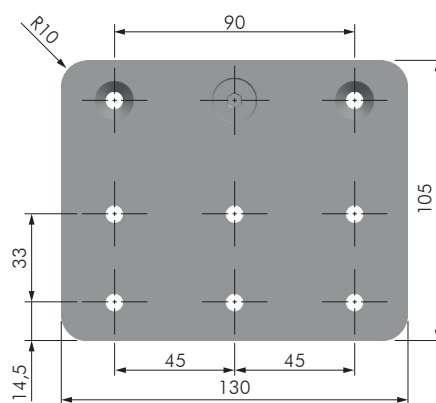
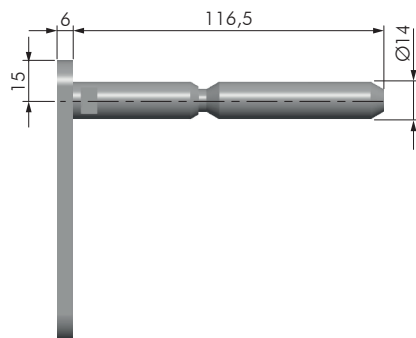

SUPPORTO BANCONE		
CODICE	MATERIALE	QUANTITÀ
91504080	FE	25

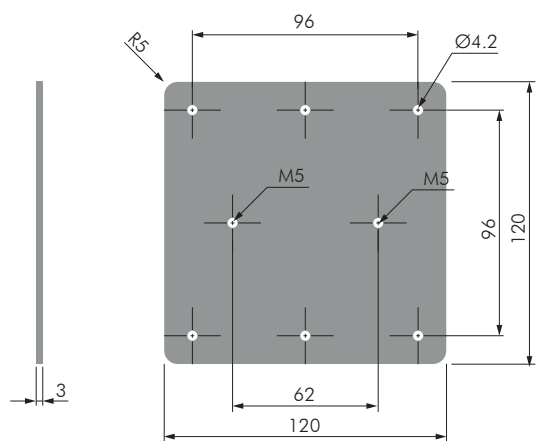

PIASTRA SUPPORTO BANCONE PER TRIADE MAXI		
CODICE	MATERIALE	QUANTITÀ
63106030	FE	100

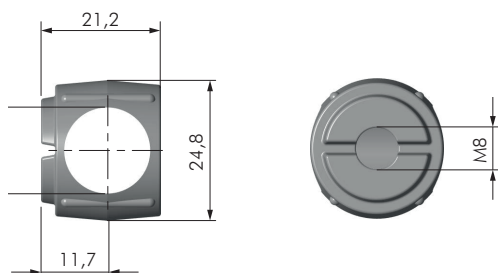

BARILOTTO		
CODICE	MATERIALE	QUANTITÀ
20914010	ZAMA	400

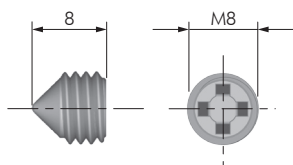

GRANO M8		
CODICE	MATERIALE	QUANTITÀ
21105070	FE	5.000

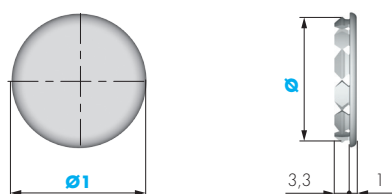

COPRIFORO A SCATTO				
CODICE	Ø	Ø1	MATERIALE	QUANTITÀ
23010010	24÷26	29	PLAST	5.000

INSTALLAZIONE SUPPORTO BANCONE PER TRIADE MAXI

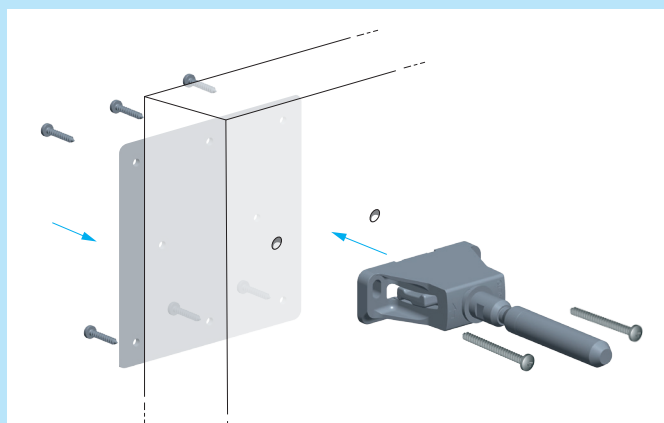

1. FISSARE LA PIASTRA SUL RETRO DEL PANNELLO CON VITI PANELVIT TC Ø3.5.

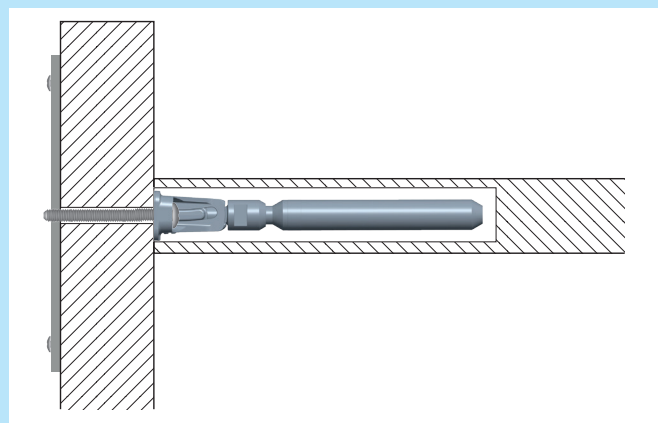

2. FISSARE TRIADE ALLA PIASTRA ATTRAVERSO I FORI PREDISPOSTI NEL PANNELLO TRAMITE VITI TC M5.