

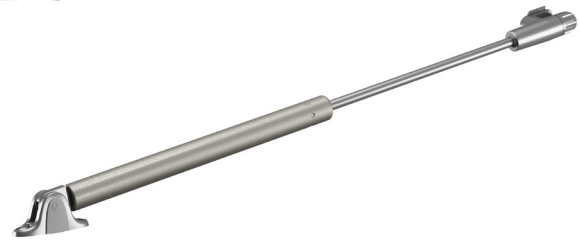

CARATTERISTICHE:

- Elemento d'arredo compatto e versatile.
- Soluzione salvaspazio.
- Consente l'apertura ammortizzata dell'anta di appoggio garantendone stabilità e resistenza.

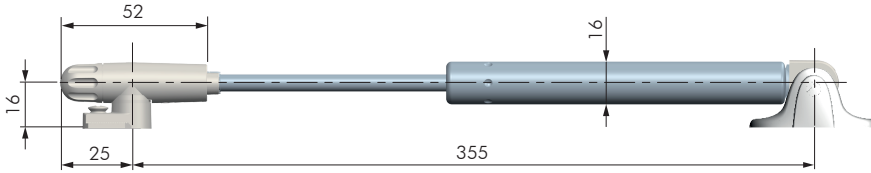

KRABY PER SCRITTOIO		
CODICE	MATERIALE	QUANTITÀ
42250031	ZAMA - PLAST - FE	A RICHIESTA

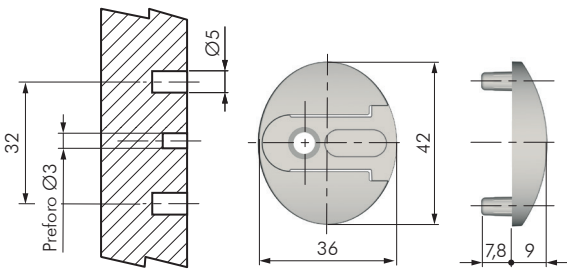

SUPPORTO PER FIANCO KRABY CON 2 PIOLINI Ø5		
CODICE	MATERIALE	QUANTITÀ
42901010	ZAMA	700

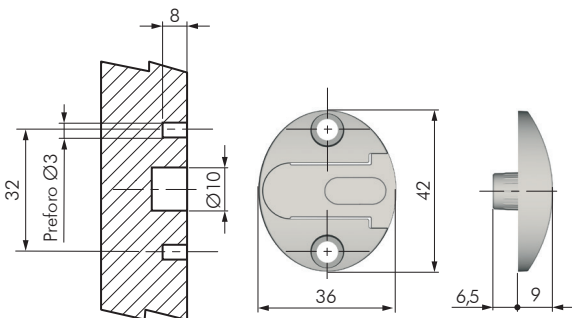

SUPPORTO PER FIANCO KRABY CON 1 PIOLINO CENTRALE Ø10		
CODICE	MATERIALE	QUANTITÀ
42901020	ZAMA	700

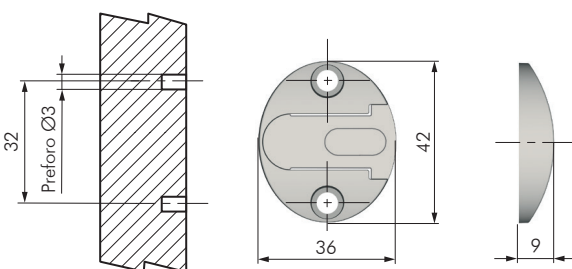

SUPPORTO PER FIANCO KRABY FISSAGGIO CON VITI		
CODICE	MATERIALE	QUANTITÀ
42901030	ZAMA	800

FORATURE

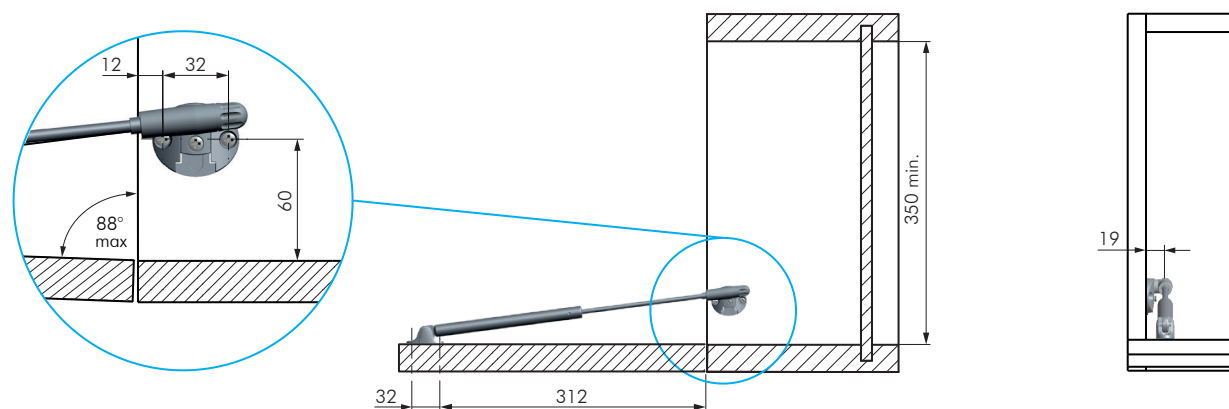

SCHEMA VALIDO CON L'USO DELLA CERNIERA KIMANA/ KIMANA SKIN.

INSTALLAZIONE KRABY PER SCRITTOIO

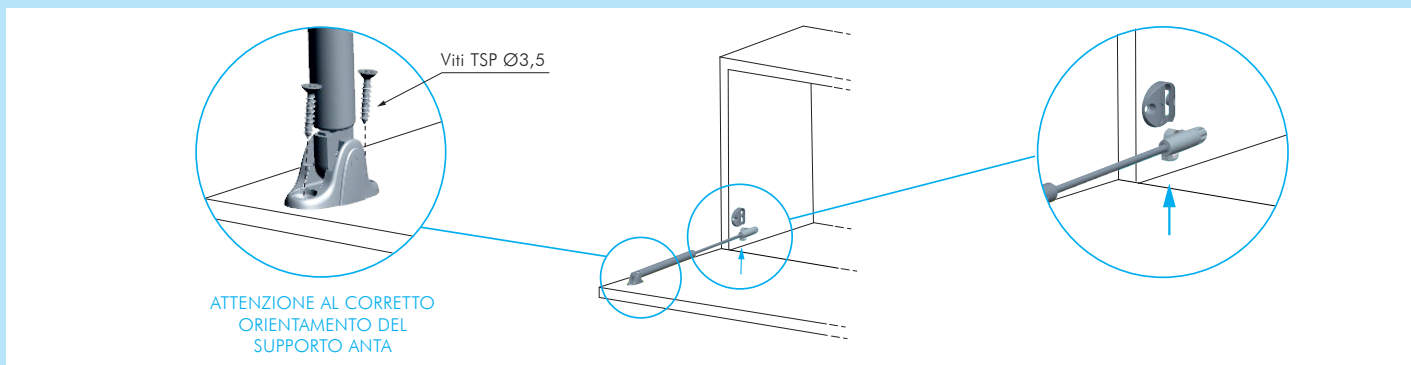

1. INNESTO FIANCO

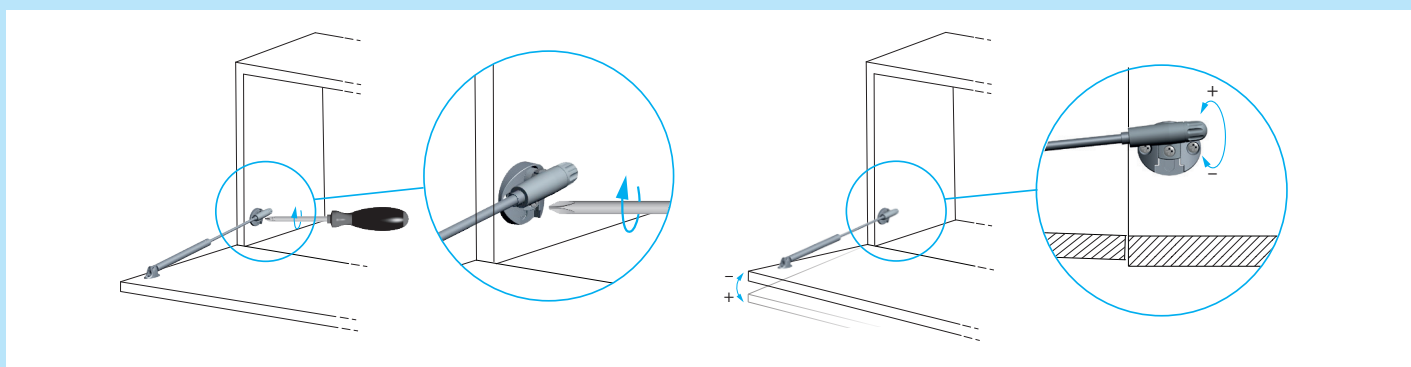

2. BLOCCAGGIO

3. REGOLAZIONE DELL'ANTA