



SCHEDA TECNICA  
**SISTEMA DI APERTURA KIARO EASY**

# KIARO EASY

- Sistema ambidestro per l'apertura delle ante a ribalta.
- Meccanismo integrato.
- Ideale per ante di peso e dimensioni ridotte.
- Disponibile nelle versioni forza Soft e forza Strong.
- Il cavo in tessuto nautico garantisce una tenuta estrema.
- Regolazione dell'angolo e del freno di apertura dell'anta.



## DIMENSIONI

### Dimensioni meccanismo

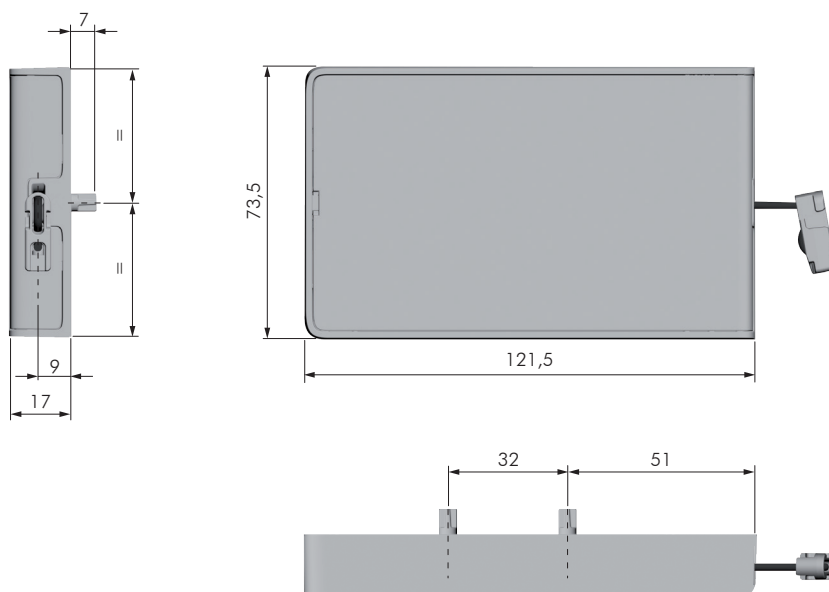

### Dimensioni supporto anta ad incasso e cover

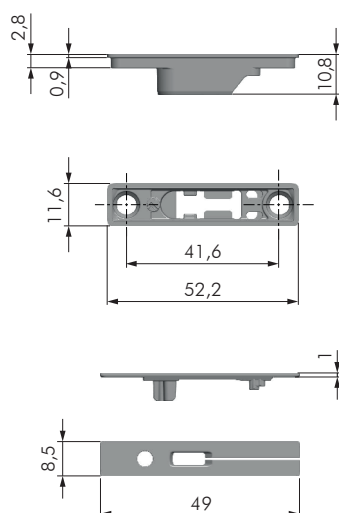

### Dimensioni supporto anta a ridosso e cover

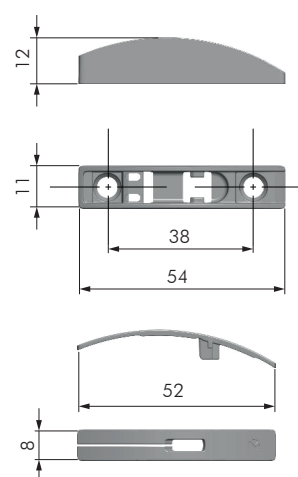

### Dimensioni supporto anta a incasso per profilo in alluminio

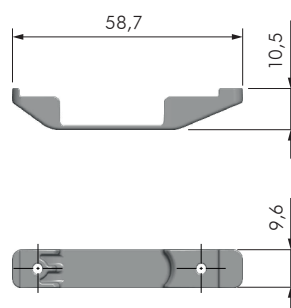

## FORATURE

### Lavorazione sul fianco

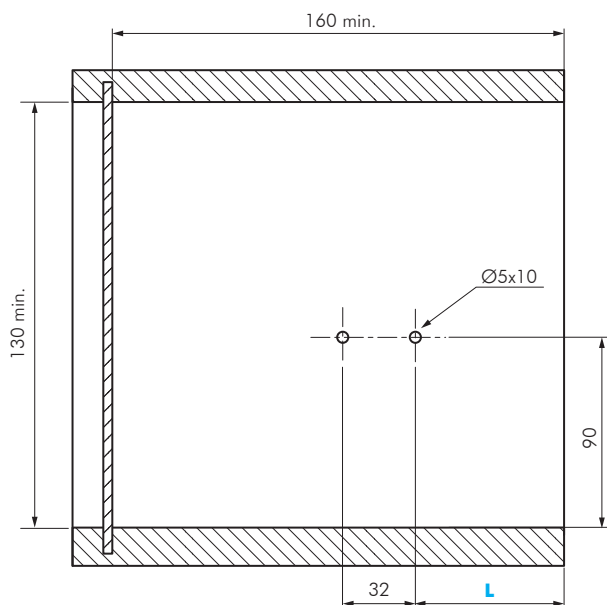

FORATURA	L
Supporto anta ad incasso	85

### Lavorazione sull' anta per supporto ad incasso

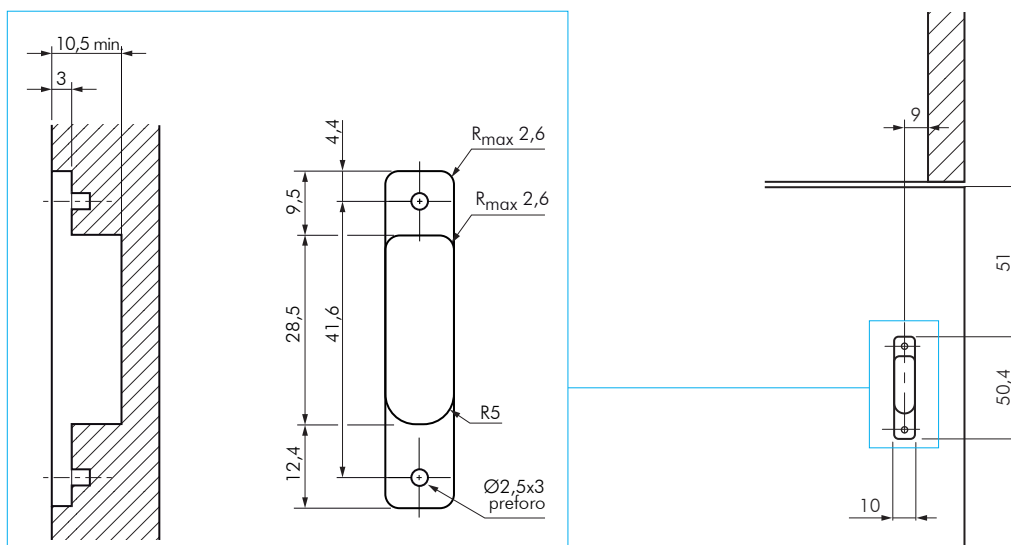

### Lavorazione sull' anta per supporto a ridosso

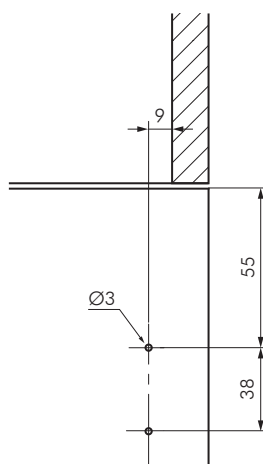

## FORATURE PROFILO IN ALLUMINIO

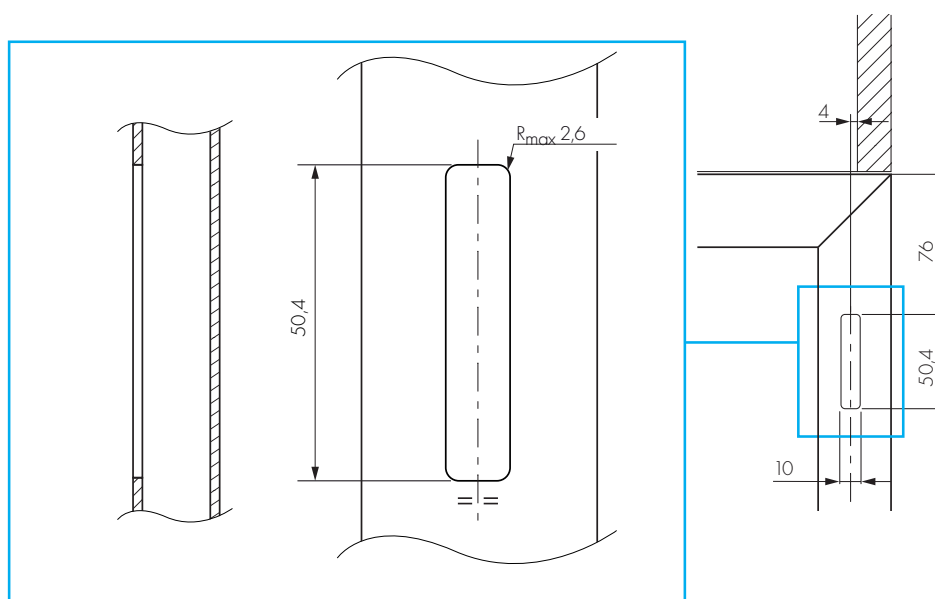

## INSTALLAZIONE ATTACCO ANTA SU PROFILO IN ALLUMINIO

STEP 1- Preassemblaggio attacco anta.

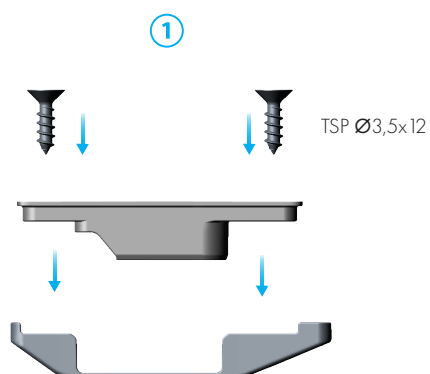

STEP 2- Posizionamento e fissaggio attacco anta.

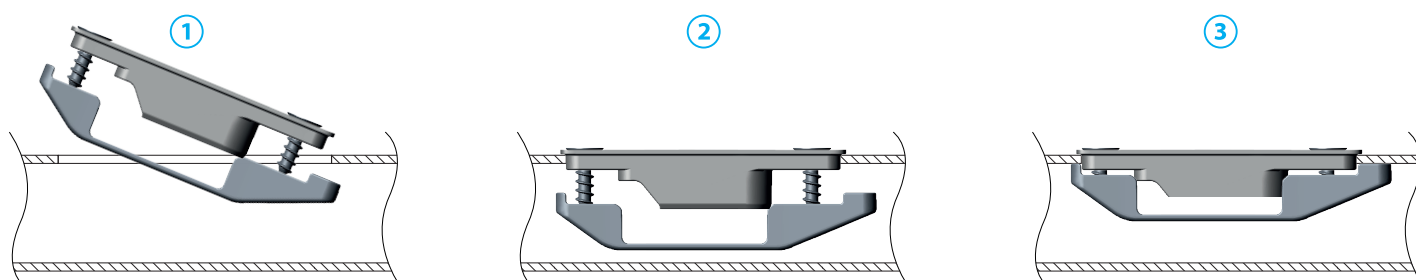

## INSTALLAZIONE

### STEP 1 - Meccanismo ambidestro

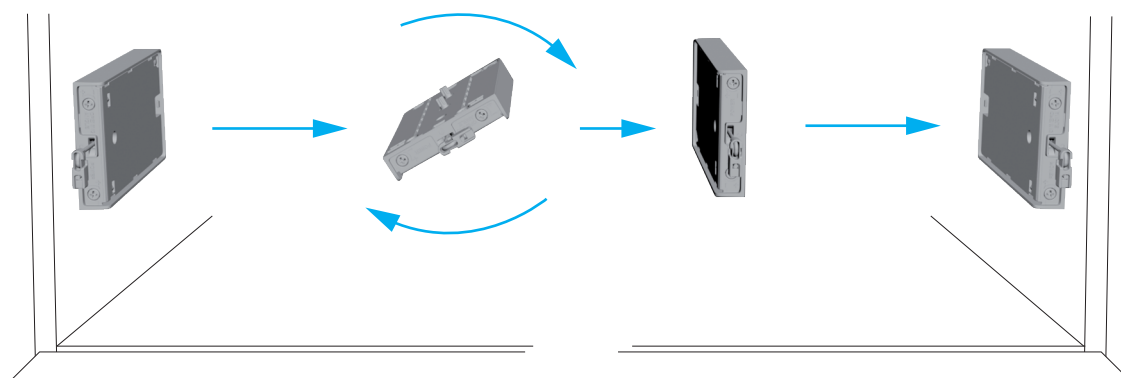

### STEP 2 - Fissaggio meccanismo e inserimento supporto

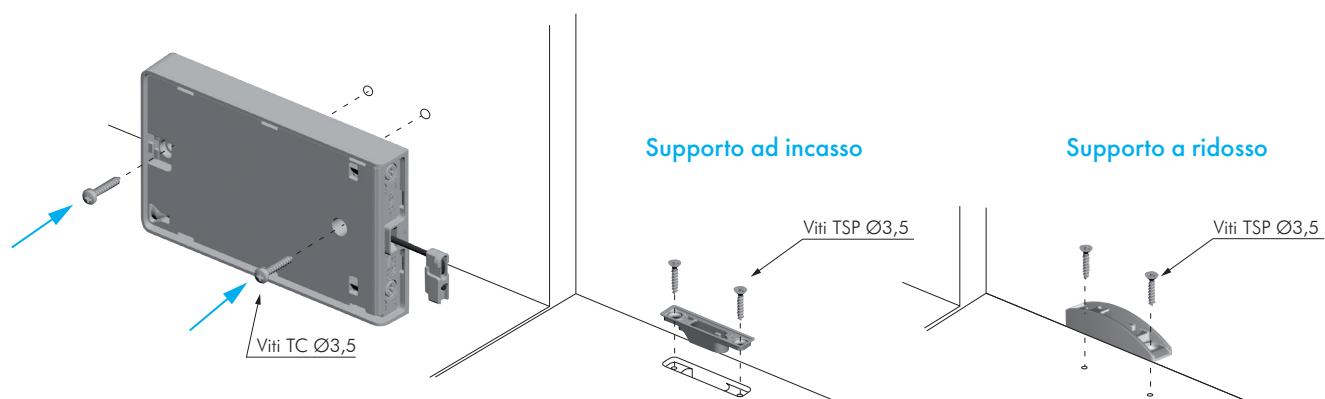

### STEP 3 - Inserimento del blocchetto nel supporto anta, ad anta semi chiusa

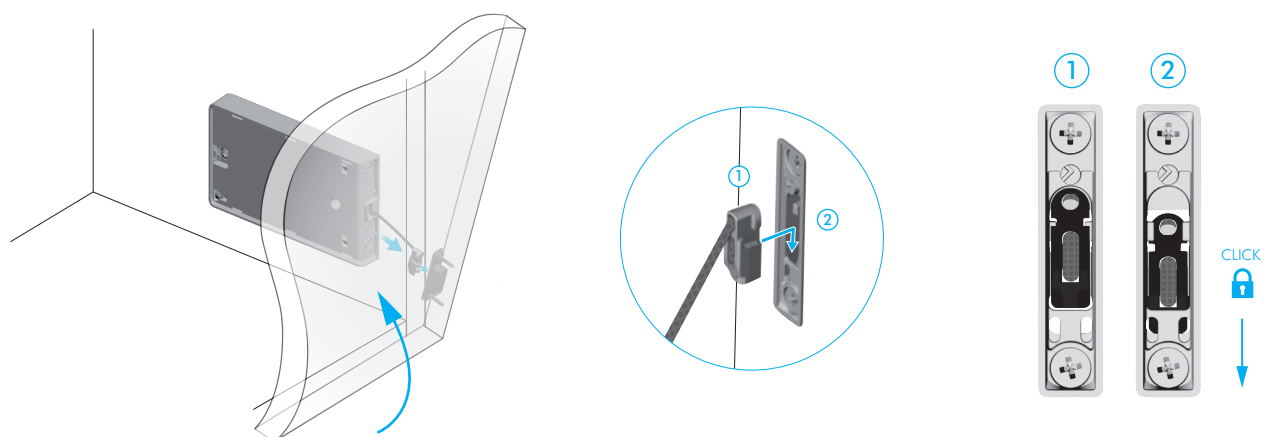

### STEP 4 - Applicazione cover anta

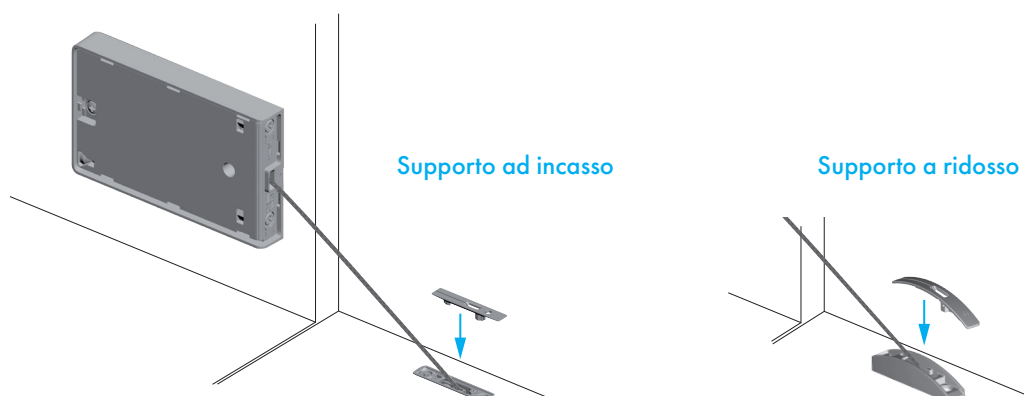

STEP 5 - Regolazione angolo di apertura anta

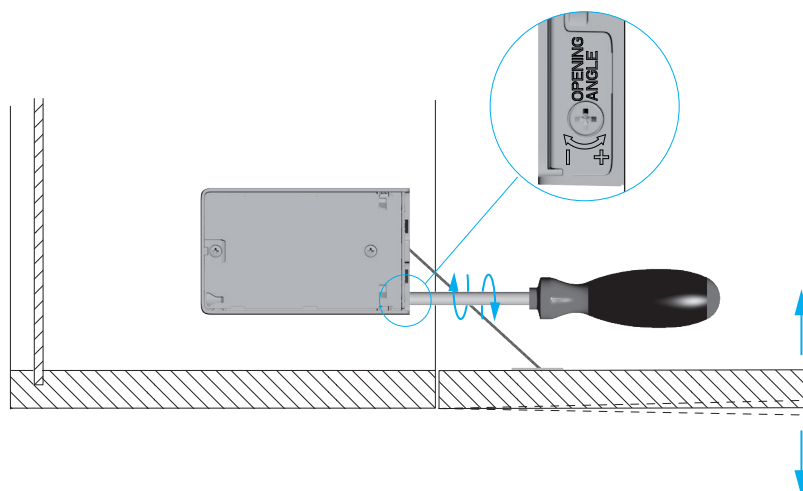

STEP 6 - Regolazione freno apertura anta

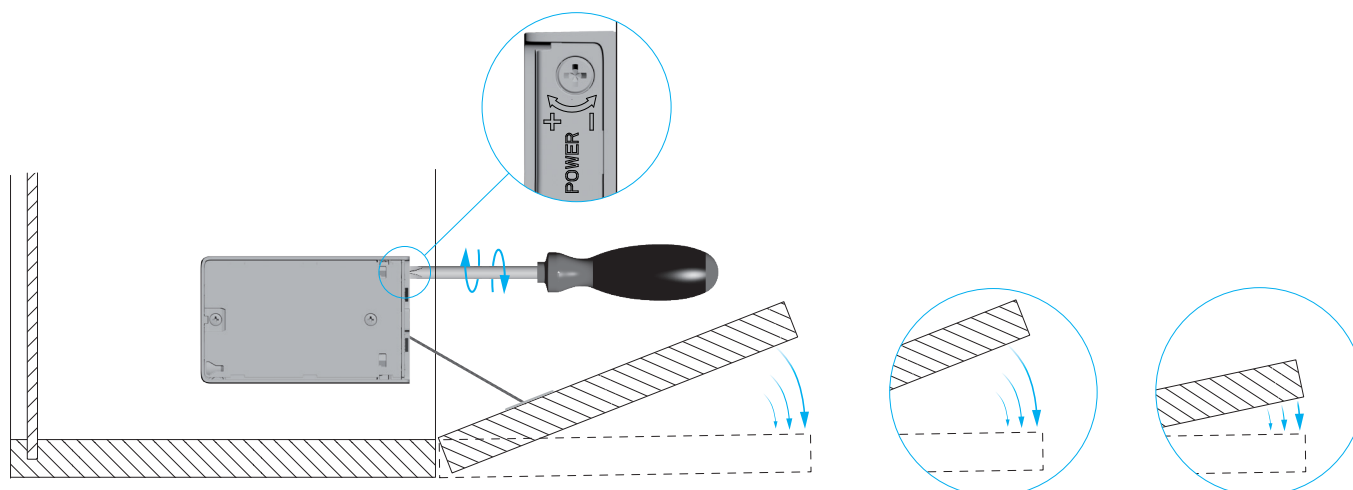

STEP 7 - Applicazione cover meccanismo

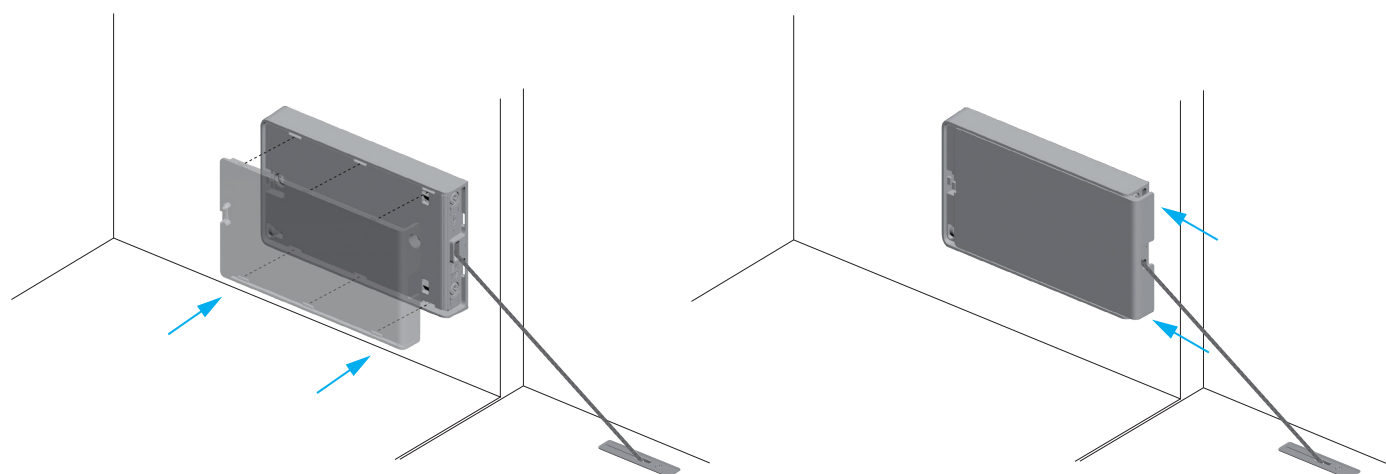

### Installazione singola con 1 Kiaro Easy

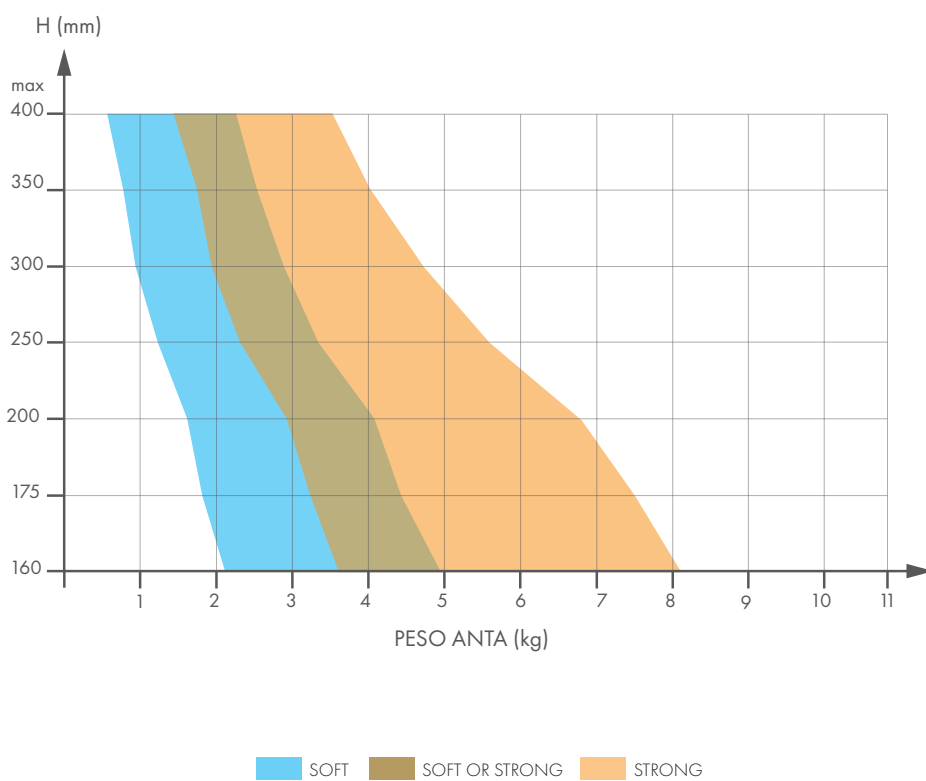

### Installazione doppia con 2 Kiaro Easy

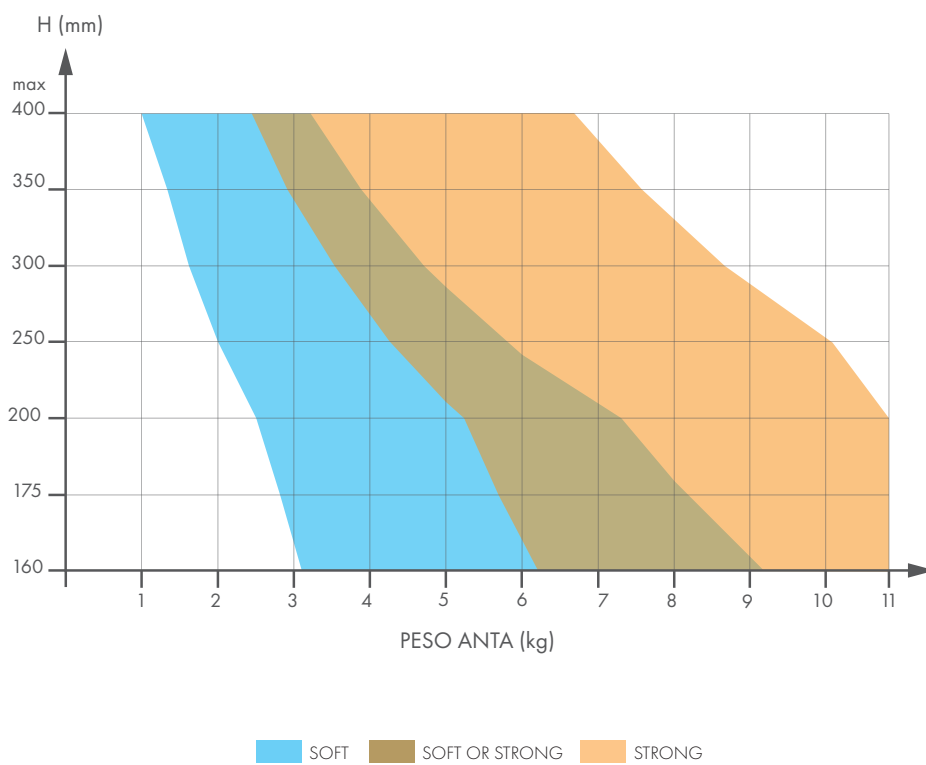

**FERRAMENTA LIVENZA SRL**

SEDE: viale L. Zanussi, 21 | 33070 Maron di Brugnera (PN)

T: +39 0434 616211 | F: +39 0434 616218

E: [info@ferramentalivenza.it](mailto:info@ferramentalivenza.it)

FILIALE: via R. Serra, 74 | 61122 Pesaro (PU)

T: +39 0721 283531 | F: +39 0721 280175

[www.ferramentalivenza.it](http://www.ferramentalivenza.it)