

TESTINA M6 TAGLIO CACCIAVITE

CODICE	L	Ø	MATERIALE	QUANTITÀ
20601010	10	12	OTT	5.000
20601020	17	11	OTT	15.000
20601030	19	11	OTT	5.000

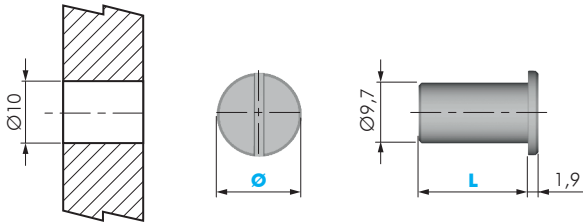

TESTINA 7÷16 TAGLIO CACCIAVITE

CODICE	L	Ø	MATERIALE	QUANTITÀ
20602020	18	14	OTT	2.000
20602030	24	15	OTT	2.000

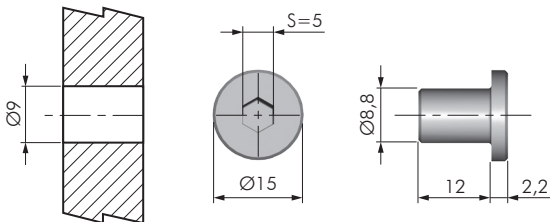

BORCHIA M6

CODICE	DESCRIZIONE	MATERIALE	QUANTITÀ
20603010	PIANA	FE	5.000
20604010	BOMBATA	FE	5.000

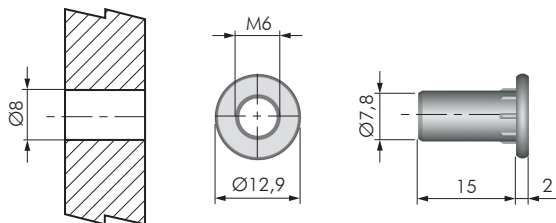

FONDELLO A PRESSIONE M6

CODICE	MATERIALE	QUANTITÀ
20701010	FE	3.000

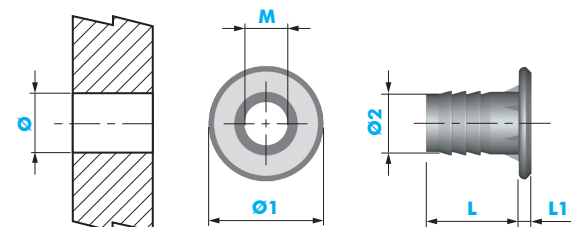

FONDELLO A PRESSIONE

CODICE	L	L1	Ø	Ø1	Ø2	M	MATERIALE	QUANTITÀ
20702010	14	1,6	8	13,8	8,7	M6	FE	2.500
20703010	14	2,2	10	19,1	10,8	M8	FE	1.500
20703020	16	2,2	10	19,1	10,8	M8	FE	1.000
20706010	16	2,2	12	19,1	10,8	M10	FE	1.000

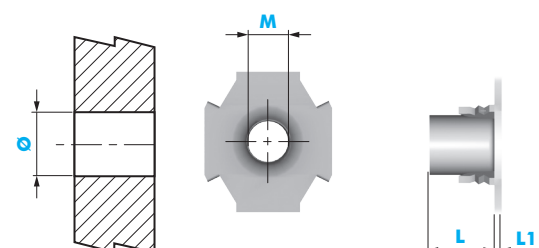

FONDELLO QUATTRO PUNTE FILETTATO

CODICE	L	L1	Ø	M	MATERIALE	QUANTITÀ
20704020	8	1	7,5	M6	FE	5.000
20705010	11	1,5	10	M8	FE	3.000
20705030	11	1,5	12	M10	FE	4.000

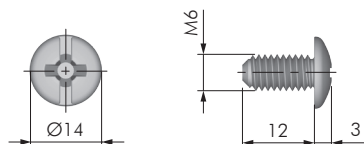

VITE TBL M6 PER TUBETTO

CODICE	MATERIALE	QUANTITÀ
20807010	FE	2.500

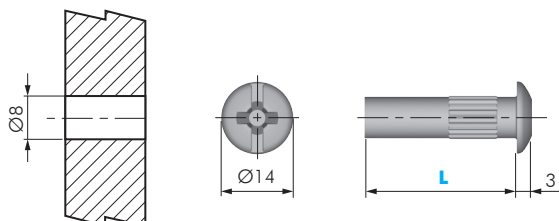

TUBETTO M6 Ø8 CON TESTA

CODICE	L	MATERIALE	QUANTITÀ
20805010	14	FE	10.000
20805040	25	FE	1.500
20805030	30	FE	1.250

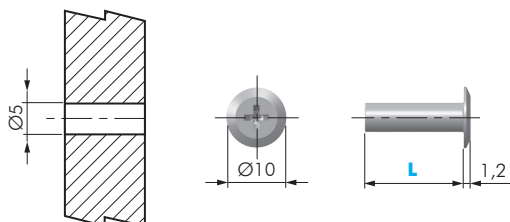

TUBETTO M4 Ø5 TESTA PIATTA

CODICE	L	MATERIALE	QUANTITÀ
20816020	16	FE	5.000
20820010	27	FE	5.000
20820020	30	FE	2.500

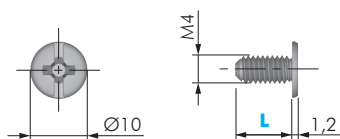

VITE TBL M4 PER TUBETTO TESTA PIATTA

CODICE	L	MATERIALE	QUANTITÀ
20817000	8	FE	5.000
20821010	12	FE	5.000
20821020	15	FE	5.000
20817010	16	FE	5.000
20817090	20	FE	5.000
20821030	22,5	FE	5.000
20821040	25	FE	5.000
20821050	27,5	FE	5.000
20821060	30	FE	5.000
20821070	32,5	FE	5.000
20817040	35	FE	5.000
20821080	45	FE	5.000
20821090	47	FE	5.000
20817140	70	FE	5.000
20817110	80	FE	5.000

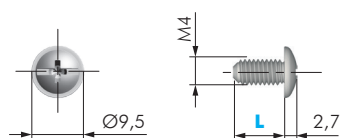

VITE TBL M4 PER TUBETTO CON FINTA RONDELLA

CODICE	L	MATERIALE	QUANTITÀ
20811010	12	FE	5.000
20811020	15	FE	5.000

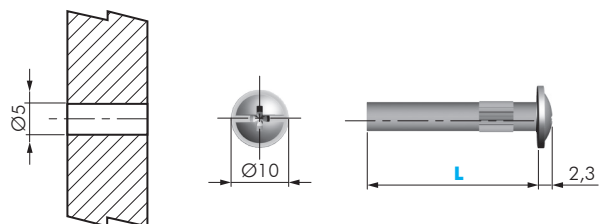

TUBETTO M4 Ø5 CON TESTA E FINTA RONDELLA

CODICE	L	MATERIALE	QUANTITÀ
20810000	15	FE	5.000
20810010	27	FE	5.000
20810020	30	FE	2.500
20810030	35	FE	2.500

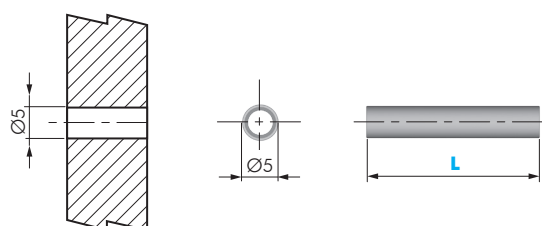

TUBETTO M4 Ø5 SENZA TESTA

CODICE	L	MATERIALE	QUANTITÀ
20801010	15	OTT	10.000
20801020	28	OTT	5.000
20801030	45	OTT	5.000
20801060	33	OTT	5.000

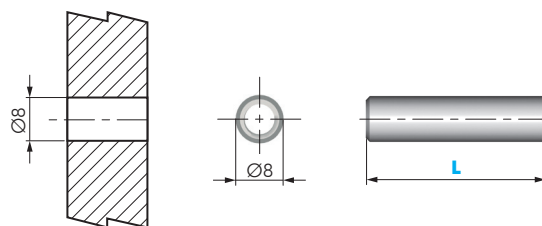

TUBETTO M6 Ø8 SENZA TESTA

CODICE	L	MATERIALE	QUANTITÀ
20803010	32	ZAMA	3.000
20803020	27	ZAMA	500

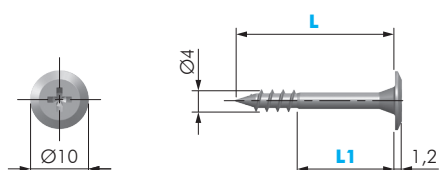

VITE TRUCIOLARE Ø4 TESTA PIATTA

CODICE	L	L1	MATERIALE	QUANTITÀ
60113060	20	9	FE	5.000
60113050	24	13	FE	5.000
60113070	25	14	FE	5.000
60113010	27	16	FE	5.000
60113020	31	20	FE	5.000

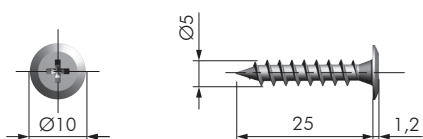

VITE PANELVIT Ø5 TESTA PIATTA

CODICE	MATERIALE	QUANTITÀ
60113040	FE	3.000

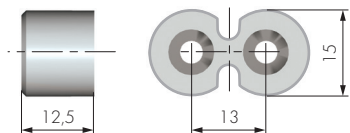

GIUNZIONE PER CORNICI

CODICE	MATERIALE	QUANTITÀ
21603010	PLAST	5.000

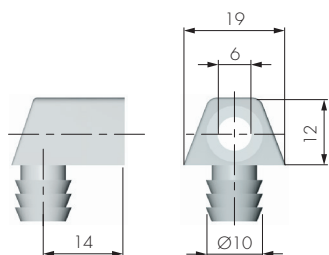

GIUNZIONE TRAPEZ

CODICE	MATERIALE	QUANTITÀ
21604010	PLAST	5.000

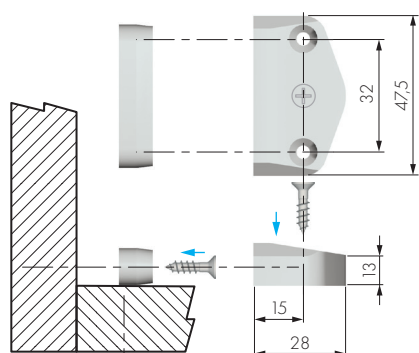

GIUNTO DA AVVITARE CON ECCENTRICO

CODICE	MATERIALE	QUANTITÀ
21606010	PLAST - FE	250

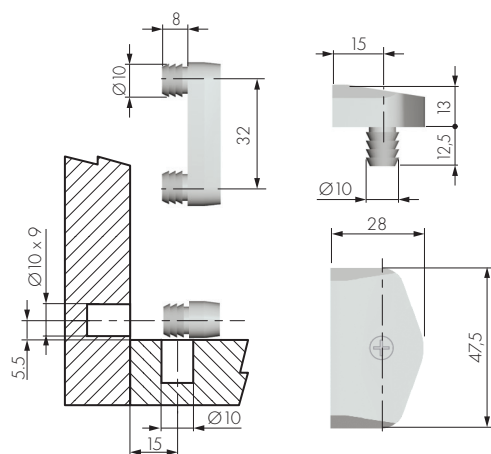

GIUNTO A RIDOSSO CON ECCENTRICO

CODICE	MATERIALE	QUANTITÀ
21607010	PLAST - FE	200

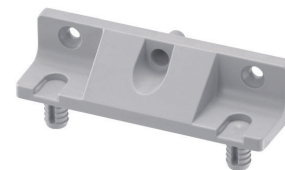
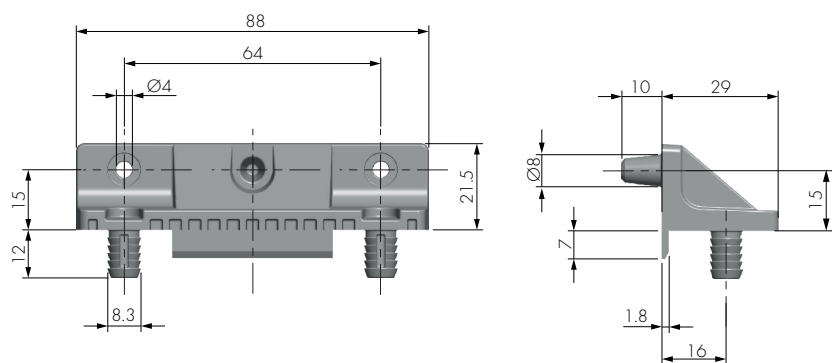

GIUNZIONE PER FRONTALINO

CODICE	MATERIALE	QUANTITÀ
21609010	PLAST	450

FORATURE

FORATURA FRONTALE

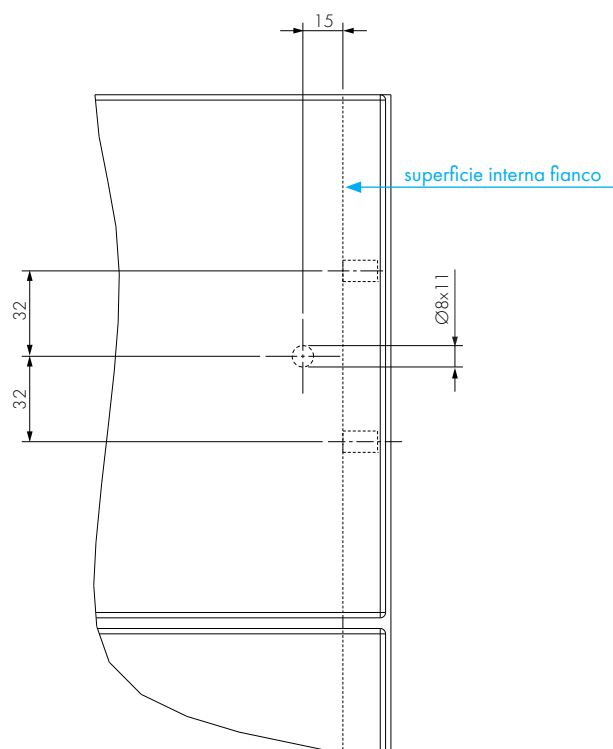

FORATURA FIANCO

